



# **ELZAB Eco Print**

## **DIGITAL LABEL PRINTING SCALE**

**Operator's Guide**

Revision 7.Eng. Modification Date 03.12.2015

## Table of Contents

Introduction.....	1
Part 1. Getting Started.....	4
1.0 Scale Operation Precaution Measures .....	4
1.1 Scale Installation.....	5
1.2 Scale General View .....	5
1.3 Quick Access Keypad .....	6
1.3.1 Quick Access Keypad (SHTRIH-PRINT and SHTRIH-PRINT M Models).....	6
1.3.2. Quick Access Keypad (SHTRIH-PRINT FI and SHTRIH-PRINT PV Models) .....	7
1.4 Numeric and Functional Keypad .....	8
1.5 Display .....	10
1.6 Scale Power-Up.....	11
1.7 Loading Paper in Printing Mechanism.....	12
1.7.1 Printing Mechanism (SHTRIH-PRINT, SHTRIH-PRINT M, and SHTRIH-PRINT FI Models) .....	12
1.7.2 Printing Mechanism (SHTRIH-PRINT PV Models) .....	13
1.7.3 Loading Paper.....	13
Part 2. Scale Operation .....	15
2.1 Selecting Items .....	15
2.1.1 Calling Up Items by PLU or Code .....	16
2.1.2 Item Search Mode .....	16
2.1.3 Calling Up Items with Quick Access Keys.....	17
2.1.4 Overriding Unit Price of Selected Item.....	17
2.1.5 Discarding Item Selection.....	18
2.1.6 Calling Up Items with Bar Code Scanner .....	18
2.2 Unit Price .....	18
2.2.1 Setting Unit Price with Numeric Keys.....	18
2.2.2 Setting Unit Price with Quick Access Keys.....	19
2.3 Entering Tare Weight .....	19
2.3.1 Measuring Unknown Tare Weight on Scale.....	19
2.3.2 Keying in Tare Weight with Numeric Keys .....	20
2.3.3 Automatic Selection of Preset Tare Weight from PLU.....	20
2.4 Non-Weight Items .....	20
2.5 Printing Labels .....	21
2.5.1 Standard Labels .....	21
2.5.2 Label Copies for Non-Weight Items.....	22
2.6. Automatic Label Printing .....	22
2.7 Grand Totals Memory.....	23
2.7.1 Add to Grand Totals Memory .....	23
2.7.2 Void from Grand Totals Memory.....	24
2.7.3 Grand Totals Mode and Grand Totals Labels .....	24
2.7.4 Change Calculation .....	25
2.8 Prepacking Mode.....	25
2.9 Additional Functions.....	26
2.9.1 Programming of Quick Access Keys.....	26
2.9.2 Saving Unit Price to Scale PLU Memory .....	27
2.9.3 Date .....	27
2.9.4 Time.....	27
2.9.5 Autoprinting Threshold .....	28
2.9.6 Currency Exchange Rate .....	29
2.9.7 Secondary Currency Cost Equivalent.....	29
2.9.8 Production Date .....	30
2.9.9 Arbitrary Bar Code.....	30
2.9.10 Other Additional Functions .....	31

2.10 Advertisement Text.....31

2.11 Functions Remotely Controlled by System Administrator.....32

    2.11.1 Clear DB/Sales Records .....32

    2.11.2 Quick DB Update Mode.....32

    2.11.3 Selected PLU Update Warning .....33

    2.11.4 Urgent Message .....33

Part 3. Errors and Troubleshooting.....34

    3.1 Power-Up Errors .....34

        3.1.1 Single Power-Up Error .....34

        3.1.2 Multiple Power-Up Errors.....35

        3.1.3 Errors List Viewing Mode.....35

        3.1.4 Troubleshooting Recommendations Display Mode .....36

        3.1.5 Power-Up Errors .....36

    3.2 Main Mode Errors.....38

    3.3 Printing Errors.....41



## Introduction

This Operator's Guide describes the use of SHTRIH-PRINT 4.5 digital label printing scales (hereinafter LP Scale or scale).

SHTRIH-PRINT 4.5 LP scales are available in five designs: SHTRIH-PRINT, SHTRIH-PRINT M, SHTRIH-PRINT FI, SHTRIH-PRINT S, and SHTRIH-PRINT PV. Each design can be produced with a vacuum fluorescent display (VFD, code D1) or a liquid crystal display (LCD, code D2). The scale is equipped with a set of interfaces (code I1) including RS-232 and Ethernet 10/100BaseT. This Operator's Guide describes the use of all designs of SHTRIH-PRINT LP scales, except for SHTRIH-PRINT S version designed for self-service operation.

The LP scale receives power from the alternating current electricity network with the voltage of ~220 V (185 to 255 V) and the frequency of 50 Hz (49 to 51 Hz). The maximum power consumption of the scale is 75 Watt. The operating temperature range is +10 to +40°C.

The main function of the scale is calculation of a product cost by its weight and unit price and subsequent printing of a label containing EAN13 bar code and various textual and graphic information. Product weight value is obtained by measuring it on the scale. Unit price is set either from the numeric keypad (manual input) or by selecting an item from the internal memory of the scale. An item stored in the internal memory of the scale contains a set of information such as item name, unit price, shelf life, etc. This information is used in various ways during weighing and printing labels, e.g. item name is indicated on the scale display and can be printed on a label. Items and unit prices can also be called up with quick access keys, if keyboard keys are properly programmed by the system administrator.

The scale has a built-in memory to store item information and additional textual information (messages). The memory allocation for items and messages is set by the system administrator. The maximum quantity of items that can be stored in the selected configuration of the scale memory is displayed during the unit power-up self-test. For example, the description "SHTRIH-PRINT 4900 F" means that the model design of the scale is "F" (Prepacking) and that the system administrator set the scale to store up to 4900 PLUs, which also allows having up to 4000 messages of 8 lines each. PLU (Price Look-Up Unit) is an element of the scale internal memory containing the following item data:

- Item Name (2 lines of 28 characters);
- Item Code (up to "999999");
- Item Unit Price (up to "9999.99", or up to "999999", if the decimal separator is to used);
- Item Shelf Life (in days, up to "9999");
- Item Preset Tare Weight Value (Tare Max Weight value is indicated on the special sticker under the display of the scale);
- Item Group Code (up to "9999"; it is possible to store Item Production Date instead of Item Group Code);
- Item Message Number (for details refer to the paragraph below);
- Item Image Number ("1".."4");
- Item Certificate Code (4 characters);
- Item Type (weight item or non-weight item);
- Item Sale Date;
- Item Priority Label Format Number (up to "15");
- Item Priority Bar Code Structure Number (up to "14");
- Item Priority Bar Code Prefix Number (up to "4").

Message is an additional textual information printed on a label that can be used for various purposes, e.g. to provide complimentary information about the store, an item, or a group of items. Each message has its unique number and contains several (4 to 30) lines of 50 characters (number of lines in a message and characters per line are set by

the system administrator). If PLU data contains an item message number, message text will be printed on a label, provided that this function is enabled in the label format selected by the system administrator. If messages are disabled, the maximum quantity of PLUs that can be stored in the scale will be 22700.

The numeric keypad of the scale is used to input:

- Code value of an item to be called up (up to “999999”);
- PLU number of an item to be called up (up to “22700”);
- Item unit price (up to “9999.99”, or up to “999999”, if the decimal separator is to used);
- Quantity of a non-weight item (up to “99”);
- Quantity of a non-weight item labels to be printed (up to “99”);
- Product tare weight value (Tare Max Weight value is indicated on the special sticker under the display of the scale);
- Amount received from a client for change calculation (up to “9999.99”, or up to “999999”, if the decimal separator is to used).

If enabled by the system administrator, it is possible to input from the numeric and the quick access keypads the following data:

- Secondary currency exchange rate (up to “999.99”);
- Item production date;
- First 12 digits of an item bar code;
- Automatic label printing threshold value (up to Max);
- Current date and time (the scale has a built-in real-time clock).

With the listed above and other data, it is possible to calculate the following:

- Item cost (up to “9999.99”, or up to “999999”, if the decimal separator is to used);
- Item cost equivalent in the secondary currency;
- Item expiration date;
- Bar code;
- Change (up to “9999.99”, or up to “999999”, if the decimal separator is to used);
- Grand totals sales amount accumulation (up to “9999.99”, or up to “999999”, if the decimal separator is to used);
- Grand totals weight accumulation (up to “65.535” kg);
- Grand totals quantity accumulation of non-weight items (up to “9999”);
- Grand totals transactions accumulation (up to “255”).

The scale is equipped with a printing mechanism with ROHM thermal head. The printer has the following characteristics:

- Horizontal and Vertical Printing Resolution – 8 dots/mm;
- Number of Dots per Line – 432 dots;
- Print Width – 54 mm;
- Paper Width – 60 mm;
- Maximum Printing Speed – 100 mm/sec;
- Thermal Head Life – 50 km.

The scale printer can use labels with the height of 30 to 120 mm and the width of 60 mm. The inner diameter of the paper roll (spool) should be 40 mm, the outer diameter of the paper roll should be no more than 120 mm. The scale should be configured by the system administrator to operate with the loaded format of label paper.

The scale can print weight items labels, non-weight items labels (and up to 99 copies of such labels), and grand totals labels with label stripping control enabled/disabled, as well as report labels.

The numbering of labels is continuous ranging from "0" to "9999". Grand totals labels and reports do not increment the label number.

## Part 1. Getting Started

### 1.0 Scale Operation Precaution Measures

**Important!** The scale must be powered from an outlet with a proper grounding. Do not use electric networks, outlets, and power cords without proper grounding – it can cause scale damage and operator injury!

**Important!** Prevent moisture from getting inside the scale while operating it! It can cause scale damage and operator injury!

**Important!** Always unplug the scale from the electric network before periodic and non-recurrent maintenance operations like cleaning the platter/pan, the keyboard, or the thermal head of the printing mechanism.

**Important!** Do not use sharp metal objects to clean the thermal head of the printing mechanism! Use the cleaning pen only! Apart from the cleaning pen, use spirit-based cleaning solutions! Before plugging the scale into the electric network, make sure there is no cleaning solution left on the thermal head! Failure to comply with the above requirements may cause thermal head damage!

**Important!** Scale is voided of warranty, if diagnosed for disregard for safety regulations and the above mentioned requirements.

**Important!** Scale does not produce any gases while operating normally!

**Important!** Scale is equipped with a lithium battery that must be replaced by an authorized service personnel only. It is prohibited to throw away used lithium battery – it has to be disposed of in a proper way. Check your regional lithium battery disposal rules.

**Important!** Scale has a nonrecoverable electric fuse. Fuse must be replaced by an authorized service personnel only.



### 1.1 Scale Installation

The scale installation site should not prevent customers from observing the alpha-numeric display and the load receptor of the scale. Air flow from air conditioning systems or doorways should not influence scale operation. SHTRIH-PRINT, SHTRIH-PRINT M, and SHTRIH-PRINT FI scales should be placed on an even (preferably horizontal) and firm surface. The installation surface should not be subject to significant vibrations.

### 1.2 Scale General View

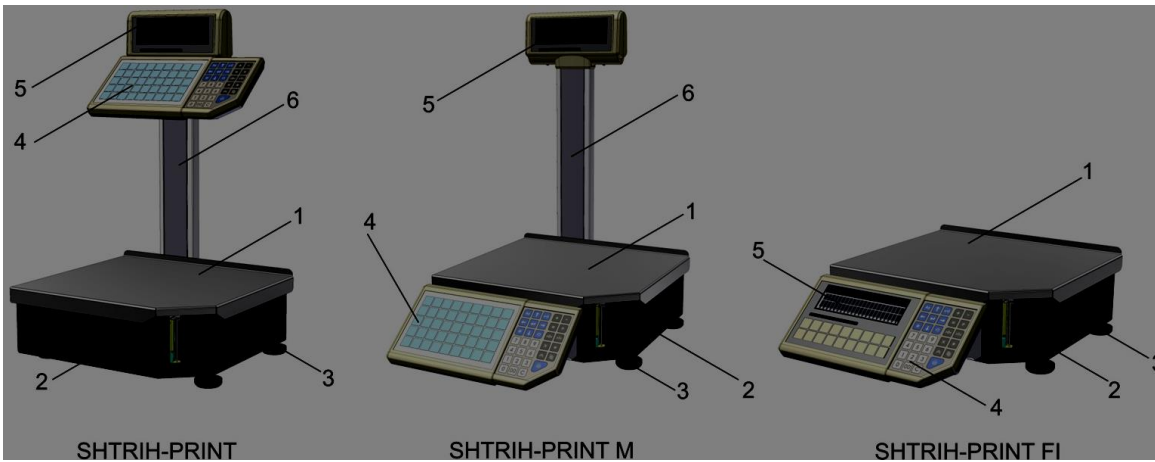

Illustration 1

[Illustration 1](#) above shows the main elements of the scales SHTRIH-PRINT, SHTRIH-PRINT M, and SHTRIH-PRINT FI:

1. Load Receptor (hereinafter “Platter”);
2. Scale Housing;
3. Scale Feet;
4. Keyboard;
5. Alpha-Numeric Indication (hereinafter “Display”; SHTRIH-PRINT and SHTRIH-PRINT M models come with a double-sided display indication);
6. Pole.

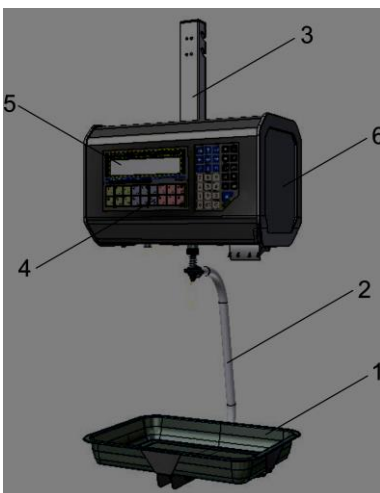

Illustration 2

[Illustration 2](#) shows the main elements of SHTRIH-PRINT PV model:

7. Load Receptor (hereinafter “Pan”);
8. Pan Suspension;
9. Scale Suspension;
10. Keyboard;
11. Alpha-Numeric Indication (hereinafter “Display”);
12. Side Door to access the power switch and the printer.

## 1.3 Quick Access Keypad

### 1.3.1 Quick Access Keypad (SHTRIH-PRINT and SHTRIH-PRINT M Models)

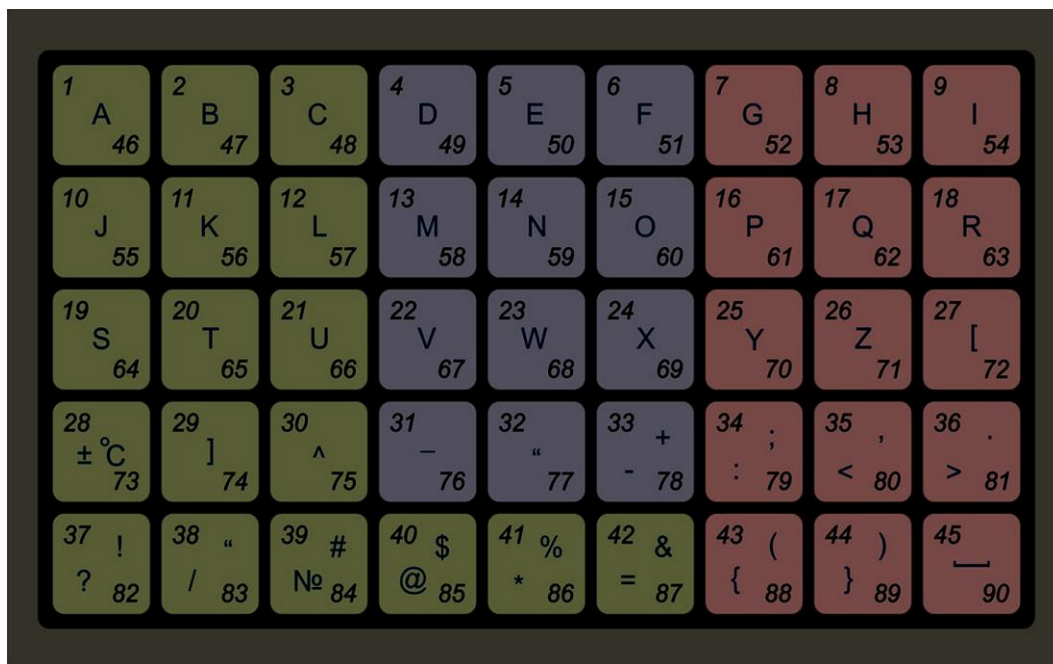



Illustration 3



The keys   are designed to provide quick access to preset items, price values, and to call up certain functions (see [Illustration 3](#)). All quick access keys are divided into three unequal groups marked with different colors. This can be useful when programming quick access to items of the same group, for example, access to different kinds of fish can be programmed by hot keys of blue color (refer to paragraph 2.9.1 Programming of Quick Access Keys).

If the display tag **REG** is off (refer to paragraph 1.5 Display), quick access keys have numbers "1".."45", otherwise the keys have numbers "46".."90".

Each quick access key can be set by the system administrator to do one of the following functions:

- Call up an item by its code;
- Call up an item by its PLU number;
- Return a preset price value;
- Enter Date Program Mode to edit date in the internal real-time clock of the scale;
- Enter Time Program Mode to edit time in the internal real-time clock of the scale;
- Enter Currency Exchange Rate Program Mode;
- Enter Automatic Printing Threshold Program Mode;
- Enter Item Production Date Program Mode;
- Enter Arbitrary Bar Code Input Mode;
- Turn on/off Secondary Currency Cost Equivalent Mode;
- Turn on/off Prepacking Mode;
- Call up functions modifying scale parameters (e.g. print contrast, label offset adjustment, label format selection).

Contact the system administrator to know how the quick access keys are programmed in your scale.

### 1.3.2. Quick Access Keypad (SHTRIH-PRINT FI and SHTRIH-PRINT PV Models)

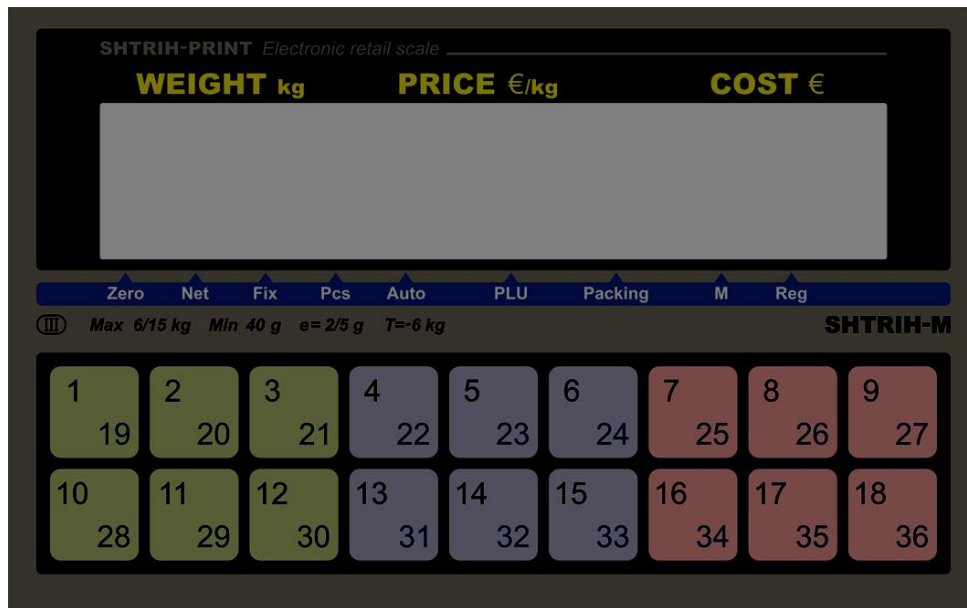





Illustration 4

The keys  ...   are designed to provide quick access to preset items, price values, and to call up certain functions (see [Illustration 4](#)). All quick access keys are divided into three equal groups marked with different colors. This can be useful when programming quick access to items of the same group, for example, access to different kinds of meat can be programmed by hot keys of red color (refer to paragraph 2.9.1 Programming of Quick Access Keys).

If the display tag **REG** is off (refer to paragraph 1.5 Display), quick access keys have numbers “1”..“18”, otherwise the keys have numbers “19”..“36”.

Each quick access key can be set by the system administrator to do one of the following functions:

- Call up an item by its code;
- Call up an item by its PLU number;
- Return a preset price value;
- Enter Date Program Mode to edit date in the internal real-time clock of the scale;
- Enter Time Program Mode to edit time in the internal real-time clock of the scale;
- Enter Currency Exchange Rate Program Mode;
- Enter Automatic Printing Threshold Program Mode;
- Enter Item Production Date Program Mode;
- Enter Arbitrary Bar Code Input Mode;
- Turn on/off Secondary Currency Cost Equivalent Mode;
- Turn on/off Prepacking Mode;
- Call up functions modifying scale parameters (e.g. print contrast, label offset adjustment, label format selection).

Contact the system administrator to know how the quick access keys are programmed in your scale.

### 1.4 Numeric and Functional Keypad



Illustration 5

**0 9** These keys are used to input numeric values (for example, unit price, PLU number, etc.).

**C** This key deletes entered numeric values like unit price of a weight item being weighed, or unit price and quantity of a non-weight item in Non-Weight Item Mode. If editing unit price of a selected item is not allowed, this key discards item selection. Keeping the key pressed longer than one second also discards item selection.

**>0<** This key is used to set the weight value to zero. Before pressing the key, make sure that there is no weight on the platter/pan. After the weight value has been set to zero, the display tag **ZERO** turns on (refer to paragraph 1.5 Display).

**>T<** This key switches on Tare Weight Selection Mode. If the display tag **REG** is off, the tare weight value is set by weighing it on the scale. If the tag **REG** is on, the tare weight value is entered manually with numeric keys. Upon switching on Tare Weight Selection Mode, the scale begins to display the net weight (the net weight equals to the gross weight minus the weight of the selected tare), the display tag **NET** turns on.

**×** This key allows entering Non-Weight Item Mode. It is also used to select Price Editing Submode and Quantity Editing Submode in Non-Weight Item Mode. It is possible to enter Non-Weight Item Mode, if the display tag **ZERO** is on and the tag **PLU** is off (meaning that no item has been selected). The scale automatically turns on and off Non-Weight Item Mode, when a non-weight item is selected or discarded.

**P** This key switches on Change Calculation Mode. The scale enters Change Calculation Mode, only if the display tag **M** is on.



**+** This key adds the current sales transaction (cost and optionally weight/quantity value of an item) to the grand totals (GT) memory and increments the number of sales transactions stored in the GT memory. The scale can simultaneously add a sales transaction to the GT memory and print a label, if this option is enabled by the system administrator. The first sales transaction added to the GT memory, turns on the display tag **M**.

**-** This key voids the last sales transaction added to the grand totals (GT) memory. Double-pressing the key does not void the sales transaction added to the GT memory before the last sales transaction.

**=** The key switches on Grand Totals Mode. The scale enters Grand Totals Mode, only if the display tag **M** is on.

 This key switches on Quick Access Keys Program Mode, if the display tag **REG** is off. If the display tag **REG** is on, the key switches on Save Item Price to Scale PLU Memory Mode.



 This key discards the selection of an item (the inductor **PLU** switches off) or cancels the last executed command, for example, it can cancel switching on Quick Access Keys Program Mode.







 This key selects between the upper and the lower case of the keyboard. The display tag **REG** is on, if the upper case of the keyboard is switched on. The status of the display tag **REG** determines the functioning of the keys , , and the quick access keys.

 This key locks and unlocks the keyboard. If the keyboard is locked, it is possible to weigh products and automatically print labels (when the display tag **AUTO** is on, refer to paragraph 2.6. Automatic Label Printing). If the keyboard is locked, the scale emits a short double-beep sound whenever any other key is pressed and displays a message “Keyboard locked!”.

 This key is used to print labels. It is possible to print a label, if the paper is properly loaded in the printing mechanism (refer to paragraph 1.7 Loading Paper in Printing Mechanism), product weight has been measured, the display tag **FIX** is on, and the calculated product cost value is not zero.

 This key selects a preset item by its PLU number or its code (depending on which option is enabled) and turns on Item Search Mode.

 This key provides access to the System Menu and confirms data input in Main Mode. Upon entering the System Menu, the scale requests a password. It is possible to return to Main Mode by pressing the key .

, , ,  These keys provide navigation in Item Search Mode and allow to comfortably view the information displayed in Main Mode. Keeping the keys  and  pressed longer than one second in Main Mode scrolls the name of a selected item to the end and back.

 This key prints several (up to 99) copies of a non-weight item label with label stripping control enabled/disabled.

 This key feeds paper and positions the thermal head at the beginning of a label.

The scale produces a beep sound whenever any key is pressed (if it does not, please contact the system administrator). A short beep sound confirms a successful pressing of a key. A long beep sound signals about an error or indicates that a key cannot be used in the current mode. The message “Keyboard locked!” and a short double-beep sound emitted by the scale when any key is pressed indicate that the keyboard has been locked with the key  or by the system administrator from the PC.

## 1.5 Display



Illustration 6

The display of the scale (see [Illustration 6](#)) has two lines containing various information. In Main Mode, the upper line of the display shows the following information (left to right):

- Weight of a product being measured, in kg, or quantity of a non-weight item, in pcs;
- Product unit price, Euro per kg/pc;
- Calculated cost of a product, if the calculation is possible.

The second line of the display contains various information, but in Main Mode it displays the name of a selected item.

The bottom part of the display contains bright triangles which are called “display tags”. The name of each display tag is indicated right underneath. The description of the tags is as follows.

**ZERO:** Indicates an empty platter/pan (product weight equals to zero). If there is weight on the platter/pan, the tag goes off.

**NET:** This display tag is on in Tare Weight Selection Mode, in which the weight indicator displays the net weight.

**FIX:** The display tag is on, if the weight value is stable and the measured weight value is in the range between Minimum capacity (Min) and Maximum capacity (Max). In this case it is possible to print a label, if this option is enabled in the System Menu (check it with the system administrator). Min and Max values are indicated on the special sticker under the display.

**PCS:** This display tag is used only in Non-Weight Item Mode. The tag is on in Quantity Editing Submode. The tag is off in Price Editing Submode.

**AUTO:** This display tag indicates that the automatic label printing function is enabled (refer to paragraph 2.9 Additional Functions).

**PLU:** This display tag shows that a PLU item has been selected.

**PACKING:** The tag shows that the scale is in Prepacking Mode (refer to paragraph 2.9 Additional Functions).

**M:** This display tag signals that the grand totals memory is not empty.

**REG:** This display tag is on, if the upper case of the keyboard is switched on (refer to paragraph 1.3 Quick Access Keypad).

**ALT:** Rightmost display tag indicating currently active keyboard layout – main (**ALT** tag is off) or alternative (**ALT** tag is on). E.g. in the English demo version, the main layout contains English characters, and the alternative layout – Russian characters. This display tag is used in the System Menu to edit string parameters.

NOTE. **ALT** display tag may not have any marking on certain localization variants of SHTRIH-PRINT scales (on English demo version, for example), though its functionality is present in all SHTRIH-PRINT scales.

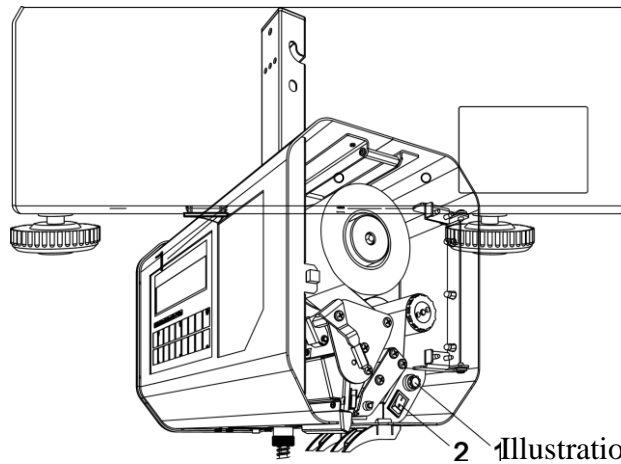

Illustration 7

2 Illustration 8

### 1.6 Scale Power-Up

[Illustration 7](#) above shows the position of the power switch **1** at the bottom of SHTRIH-PRINT, SHTRIH-PRINT M, and SHTRIH-PRINT FI scale designs.

[Illustration 8](#) above shows SHTRIH-PRINT PV hanging scale with the side door open providing access to the fuse holder **1** and the power switch **2**.

The power-up procedure of the scale is performed as follows:

- Before powering the scale up, make sure that the platter/pan is empty and does not touch any foreign objects. There should be no foreign objects underneath the platter in SHTRIH-PRINT, SHTRIH-PRINT M, and SHTRIH-PRINT FI scales, except for those foreseen by the manufacturer. The platter should be equidistant for the sides of the scale housing. The pan of SHTRIH-PRINT PV model should hang loose and should not touch any foreign objects.
- Turn on the power switch. The scale emits a series of four beeps and runs a firmware test. If the test has been successful, the scale emits one more beep sound and initiates a display test (all display registers show numbers from “0” to “9”). After the test, the scale displays the identification name of the metrologically relevant part of the scale firmware, firmware version and its digital ID (checksum), and the counter of scale calibrations (see [Illustration 9](#)):



Illustration 9

- After that the scale will display the selected configuration of the data base, scale firmware version number and development date (see [Illustration 10](#)):

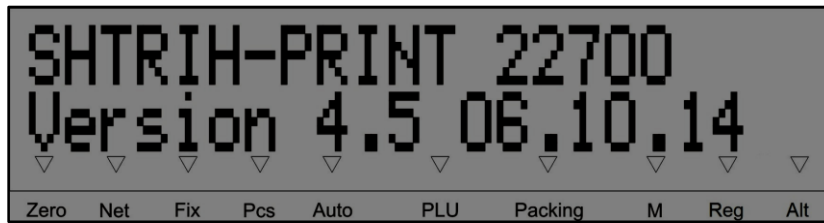



Illustration 10

- The scale then enters Main Mode. Let the scale warm up for 10 minutes before using it.
- Check the paper in the printing mechanism. If necessary, load a new paper roll (refer to paragraph 1.7 Loading Paper in Printing Mechanism).
- If the platter/pan is empty, but the weight value is fluctuating for some reason, press the key . The display tag **ZERO** will turn on.

## 1.7 Loading Paper in Printing Mechanism

### 1.7.1 Printing Mechanism (SHTRIH-PRINT, SHTRIH-PRINT M, and SHTRIH-PRINT FI Models)

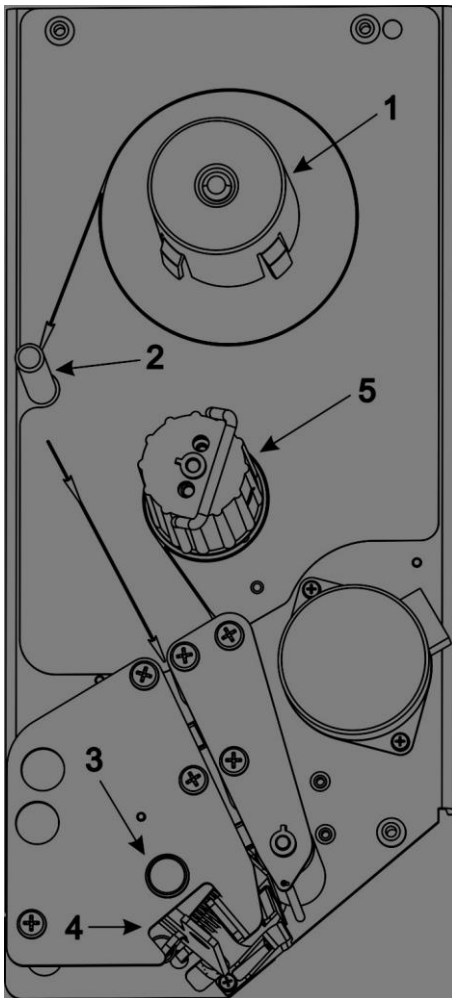

Illustration 11

To access the printing mechanism, lift the platter up. Please see [Illustration 11](#) on the left for the main view of the printing mechanism:

1. Feeding Unit of the Printer;
2. Guiding Post;
3. Thermal Head Release Latch;
4. Closing Levers of the Thermal Head;
5. Take-Up Unit of the Printer with the Fixing Clamp.



### 1.7.2 Printing Mechanism (SHTRIH-PRINT PV Models)

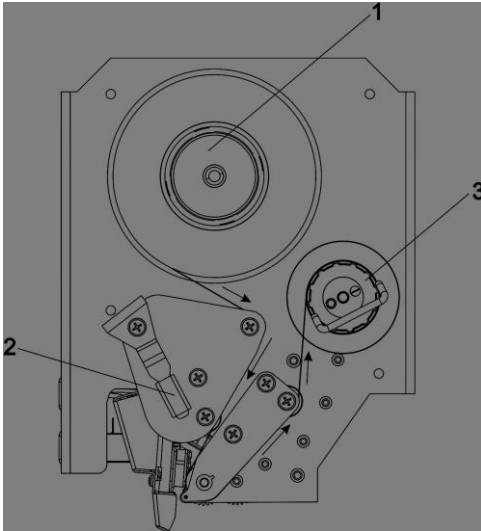



Illustration 12

To access the printing mechanism, open the side door. Please see [Illustration 12](#) on the left for the main view of the printing mechanism:

6. Feeding Unit of the Printer;
7. Lever for Opening/Closing the Thermal Head;
8. Take-Up Unit of the Printer with the Fixing Clamp.

### 1.7.3 Loading Paper

To load a new label paper roll, do the following:

- Make sure that paper characteristics of a new roll fit the printer: label length is within the range from 30 to 120 mm and the paper width is 60 mm;
- Contact the system administrator to check what label length the scale is configured to operate with;
- Remove the empty paper spool from the feeding unit of the printer **1**;
- Open the thermal head of the printer:
  - In SHTRIH-PRINT, SHTRIH-PRINT M, and SHTRIH-PRINT FI models, push the thermal head release latch **3** until you hear a click – the latch remains depressed (see [Illustration 11](#));
  - In SHTRIH-PRINT PV model, turn the lever **2** counter clockwise, the thermal head will open (see [Illustration 12](#));
- Take off the fixing clamp from the take-up unit (**5** in [Illustration 11](#) and **3** in [Illustration 12](#)) and remove the remaining paper from the mechanism;
- If you use receipt paper, take off the outer spool of the feeding unit **1** by pulling it up off the pivot **1**, then put a new receipt paper roll on the pivot of the feeding unit **1**;
- If you use label paper, fix a new label paper roll on the outer spool of the feeding unit **1** and route the paper through the printer slot. Arrows on the printer unit indicate the proper feeding direction of the paper;
- Make sure that the further edge of the paper inserted in the printer slot reaches the printer base;
- Close the thermal head:
  - In SHTRIH-PRINT, SHTRIH-PRINT M, and SHTRIH-PRINT FI models, bring together the closing levers of the thermal head **4** until you hear a click (see [Illustration 11](#));
  - In SHTRIH-PRINT PV model, turn the lever **2** clockwise, the thermal head will close (see [Illustration 12](#));
- Press the key  (if necessary, press it several times) and make sure that the paper is moving in the

right direction and labels are positioned properly;

- Wind the paper around the take-up unit of the printer (**5** in [Illustration 11](#) and **3** in [Illustration 12](#)) and fix it with the clamp. Arrows on the printer unit indicate the proper direction of winding the paper;
- Print several labels to check if the printing and feeding is OK.

NOTE. If it is not required to strip labels from the liner, do not wind the paper around the take-up unit **5** and disable the label stripping sensor. Contact the system administrator to have the label stripping sensor turned off.

**Important!** Do not use sharp metal objects to fix any troubles with printing or feeding (for example, if fragments of label or receipt paper are jammed in the printer). If necessary, clean the thermal head of the printer. Always unplug the scale from the electric network, before cleaning the thermal head, and use a cleaning pen or spirit-based cleaning solutions only! Before plugging the scale back into the electric network, make sure there is no cleaning solution left on the thermal head! Failure to comply with the above requirements may cause thermal head damage!

## Part 2. Scale Operation

The principal function of the scale is product cost calculation by its measured weight and a set unit price and subsequent printing a label. The general operating procedure is described below:

- Make sure that the platter/pan is empty and the weight value on the display is at zero. The display tag **ZERO** should be on (refer to paragraph 1.5 Display);
- Enter price of a product either manually (refer to paragraph 2.2 Unit Price), or select an item (refer to paragraph 2.1 Selecting Items);
- If it is necessary to use tare, set tare weight in one of the ways described below (refer to paragraph 2.3 Entering Tare Weight);
- If it is necessary to calculate the cost of a non-weight item with its unit price entered manually (the display tag **PLU** is off), turn on Non-Weight Item Mode (refer to paragraph 2.4 Non-Weight Items);
- Place a weight item on the platter/pan, or enter quantity of a non-weight item manually;
- Get the product cost reading; print a label, if necessary (refer to paragraph 2.5 Printing Labels). Take the product off the platter/pan;
- Proceed to processing the next product.

NOTE. It is possible to measure weight of a product before selecting it/entering unit price, if the automatic printing is disabled (the display tag **AUTO** is off). When using automatic printing, check with the system administrator, if it is possible to select an item after weighing it. Refer to paragraph 2.6. Automatic Label Printing for details.

### 2.1 Selecting Items

If an item is programmed in the memory of the scale, there are several way to call it up. The first way is to select an item by its PLU number or by its code number. Contact the system administrator to know, which option is enabled in the scale. The second way is to select an item by pressing a corresponding quick access key (keys should be properly programmed in advance). Contact the system administrator to find out how quick access keys are programmed in the scale. The third way to select a product is to enter Item Search Mode. It is also possible to call up an item with a bar code scanner connected to the scale. All these methods are described below. Regardless of the method of selecting an item, once an item is selected, the display tag **PLU** turns on, and the item unit price and the first line of its name are displayed (see [Illustration 13](#) below):

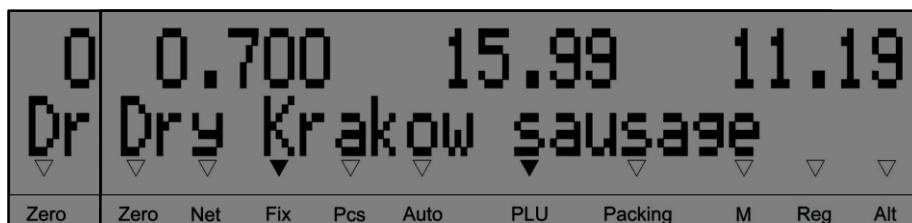



Illustration 13

If item information contains preset item tare weight, the line with the name of the product will begin with the item tare weight value and a prefix "PT:".

To display the second line of an item name (see [Illustration 14](#)), press the key :

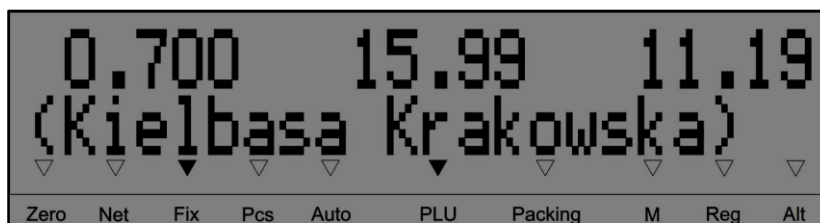









Illustration 14

To display the first line of the item name again, press the key .

The both lines with an item name, if they do not fit the display, can be scrolled to the right and to the left with the keys  and . Keep these keys pressed for more than one second to scroll the lines to the very end and to the very beginning.

### 2.1.1 Calling Up Items by PLU or Code

To select an item by the PLU number or the code number, do the following:

- The display tag **PLU** must be off, unit price value must be zero, otherwise press the key  to discard item selection, or the key  to delete unit price value.
- To select an item by the PLU number, enter its PLU number with the numeric keys and press  – the scale will find an item, display its unit price and the first line of its name; the tag **PLU** will turn on.
- To select an item by its code number, enter the code number with the numeric keys and press . The scale will first display a message “Searching...”, and then, if the scale succeeds to find the requested item, it will display the unit price and the name of the selected item; the tag **PLU** will turn on. If the scale fails to find the requested code, the scale will emit an error beep and display a message “Item not found!”.

NOTE. The PLU number and the item code number are different notions. The PLU number is a number of a memory slot in the internal memory storage of the scale. The item code is a unique identifier of an item, stored in the scale memory along with other characteristics of this item like its unit price, name, etc. When selecting an item by its code, the scale is searching its memory for the first item with the requested code. If for some reason there is more than one item with the same code number in the scale memory, the scale returns an item with the smallest PLU number.

### 2.1.2 Item Search Mode

Item Search Mode provides for browsing items stored in the PLU memory of the scale. Press the key  to enter Item Search Mode:

- If any item has already been selected (the display tag **PLU** is on), the browsing begins with the selected item.
- If no item has been selected (the display tag **PLU** is off) and no unit price has not been entered, the browsing begins with the item with the PLU number “1”.

In Item Search Mode, the scale shows PLU and code numbers of the items in the first line of the display and a item name or unit price in the second line of the display (see [Illustration 15](#) below):

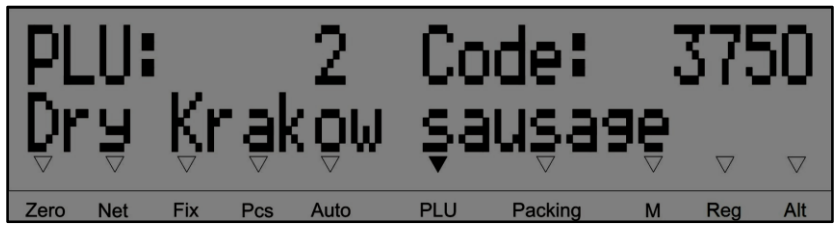

Illustration 15

To select a displayed item for processing, press the key – the scale will quit Item Search Mode and the displayed item will be selected. To quit Item Search Mode without selecting an item, use the key . Browsing in Item Search Mode:

- Keys and are used to go from one PLU number to the next and back;
- Keys and are used to switch between the first and the second lines of an item name and the unit price;
- Key discards the entered PLU number;
- It is possible to enter PLU number with the numeric keys.

### 2.1.3 Calling Up Items with Quick Access Keys

Contact the system administrator to check how the quick access keys are programmed in your scale and what items correspond with what quick access keys. Numbers of quick access keys depend on the status of the display tag **REG** (refer to paragraph 1.3 Quick Access Keypad). It may be necessary to change the status of the display tag **REG** with the key before selecting a product. Then select a product by pressing a corresponding quick access key.

### 2.1.4 Overriding Unit Price of Selected Item

Contact the system administrator to check if the scale is programmed to override unit price of a selected item, when the display tag **PLU** is on (this option can be disabled).

To override unit price of a selected item:

- Delete the preset unit price by pressing the key ;
- Enter a new unit price of the item with the numeric keys .. .

NOTE. Overriding item unit price this way does not modify the unit price of the item stored in the PLU memory of the scale and does not automatically save the new unit price in the scale memory. Paragraph 2.9.2 Saving Unit Price to Scale PLU Memory covers the saving procedure of a modified unit price.

### 2.1.5 Discarding Item Selection

Item selection can be discarded by pressing the key , as well as by keeping the key pressed for more than one second. The system administrator can program several ways of automatically discarding item selection:

- Discard a selected item after a standard label has been printed/automatically printed (refer to paragraph 2.5.1 Standard Labels);
- Discard a selected item after a period of idle waiting (idle waiting is a period of time over which the scale operator has not changed the weight on the platter/pan and has not pressed any key).

### 2.1.6 Calling Up Items with Bar Code Scanner

Connect a bar code scanner to the scale, and scan a bar code containing the code of an item it is necessary to select. Depending on the settings of the scanner, it will read the bar code immediately upon pointing the laser beam at it or after pressing the scan button on the scanner. Contact the system administrator to check how exactly your scanner is programmed to operate. The scanned bar code will be transmitted to the scale. The scale will display a message "Searching...", and if the item with the scanned code is found, the scale will display the item unit price and the name and will turn on the display tag **PLU**. If the item is not found, the scale will emit an error beep, report a message "Item not found!", and display the previously selected item.

NOTE. When selecting an item with a bar code scanner, the scale is actually searching its memory for an item with the code contained in the scanned bar code. The scale is searching for the first item with a matching code. If for some reason there is more than one item with the matching code in the scale database, the scale will return the item with the smallest PLU number.

**Important!** If a bar code read by the scanner has a structure different from the one programmed in the scale for printing bar codes on labels, item search results may be invalid. In case of an item search failure, contact the system administrator to check, if the failed bar code structure conforms the scale settings.





## 2.2 Unit Price

It may be necessary to enter unit price of a product, when information required for labeling and selling a product is not programmed in the scale memory. When unit price is set manually, some product information like its name, code, shelf life, etc. remains undefined and it is only possible to calculate cost of a product. Thus, the label printing function for a product not stored in the PLU memory of the scale (the display tag **PLU** is off) can be disabled by the system administrator.

There are two methods to set unit price: using the numeric keypad and the quick access keys.

### 2.2.1 Setting Unit Price with Numeric Keys

To set unit price of a product not stored in the PLU memory of the scale, follow the procedure:

- If the display tag **PLU** is on, discard the previously selected item by pressing the key ;
- If there has been set any other unit price of any other product, delete it with the key ;
- Using the numeric keys  , set the required unit price.

### 2.2.2 Setting Unit Price with Quick Access Keys

Contact the system administrator to find out how quick access keys of your scale are programmed (i.e. what

preset unit price values correspond with what quick access keys). Numbering of quick access keys depend on the status of the display tag **REG** (refer to paragraph 1.3 Quick Access Keypad). It may be necessary to change the status of the display tag **REG** with the key  before setting unit price. Then select the required unit price value by pressing a corresponding quick access key.

## 2.3 Entering Tare Weight

Tare weight is used when it is impossible to measure the weight of an item without tare or when an item is prepackaged with tare of a preset value. A scale operator has to enter tare weight, so that the scale could calculate the net weight of the item. In this case, the gross weight of a product (the total weight of the measured item together with the tare) should not exceed Max. Max and Tare Max Weight parameters of the scale are indicated on the special sticker under the display. After tare weight has been entered in one of the foreseen methods, the display tag **NET** switches on and the scale displays the net weight of the measured product. The mode in which tare weight is being entered is called Tare Weight Selection Mode.

There are three ways to enter tare weight value:



- Measure a non-preset tare weight on the scale;
- Key in tare weight value with the numeric keys;
- Automatically select a preset tare weight from PLU.

If the scale is in Tare Weight Selection Mode (the display tag **NET** is on), it is necessary to discard the previously entered tare weight value in order to enter a new tare weight value. If tare weight value has been automatically selected from a PLU, it will be discarded by deselecting the PLU. Otherwise remove the product and the tare from the platter/pan and press the key . The display tag **NET** will turn off, and the display tag **ZERO** will turn on.

NOTE. It may be sometimes necessary to override a tare weight value of an item automatically selected from a selected PLU (the display tag **PLU** is on). Use the key  to do it (to item will still be selected) and then enter a new tare weight value with the numeric keys or by measuring it on the scale. Deselecting an item with the tare weight set that way would not discard the new tare weight value.

### 2.3.1 Measuring Unknown Tare Weight on Scale

To enter unknown tare weight value by measuring it on the scale, follow the procedure:







- Make sure that the platter/pan is empty;
- If the display tag **ZERO** is off, press the key  – the tag **ZERO** will turn on;
- If the display tag **REG** is on, turn it off by pressing the key ;
- Place the empty tare on the platter/pan and wait for the weight value readings to stabilize;
- Press the key  to set the weight value to zero. The display tag **NET** turns on;
- Place an item in the tare and then put all together on the platter/pan.

NOTE. To do a series of weighing and cost calculation of miscellaneous products sharing the same tare (as well as to print labels and/or add sales amounts to the grand totals memory for every measurement), a scale operator can use the key  to repeatedly execute the tare-out operation: all the gross weight on the platter/pan will be treated as tare

weight and will be removed – the display tag **ZERO** will turn on. The operator can then add a new product to the tare and calculate its cost. The quantity of tare-out operations is unlimited. The total tare weight should not exceed the Tare Max Weight value indicated on the special sticker under the display.

### 2.3.2 Keying in Tare Weight with Numeric Keys

If it is impossible to measure tare weight on scale (for example, an item is packed with the tare), but its value is known in advance, a scale operator can key in tare weight value with the numeric keys:

- Make sure that the platter/pan is empty;
- If the display tag **ZERO** is off, press the key  – the tag **ZERO** will turn on;
- If the display tag **REG** is off, turn it on by pressing the key ;
- Press the key  – a prompt to enter tare weight value will appear on the display;
- Key in tare weight value with the numeric keys  ..  and press . The entered tare weight value will be displayed with the negative sign; the display tags **ZERO** and **NET** will turn on;
- Place an item to be weighed along with the tare on the platter/pan and do the measurement.

### 2.3.3 Automatic Selection of Preset Tare Weight from PLU



The scale is designed to automatically use a non-zero preset tare weight value of an item, stored in the PLU memory of the scale and called in one of the ways described in paragraph 2.1 Selecting Items. Thereby, the scale will display the net weight of the called up item and turn on the tag **NET**. Discarding a PLU item will drop the automatically selected preset tare weight value of that item.

NOTE. If tare weight value has been entered by weighing it on the scale or by keying it in from with numeric keys (i.e. not automatically by calling up a PLU with a preset tare weight), then the next called up PLU item with a preset tare weight value will not override the non-automatically selected tare weight value, and the scale will return an error message “Tare not set!”. Discarding a PLU item will not drop the non-automatically entered tare weight value, because it is not bound to item data in the PLU memory of the scale.

## 2.4 Non-Weight Items





Non-Weight Item Mode is specially designed for operation with non-weight items. Operating procedures in Non-Weight Item Mode differ from those of Weight Item Mode in using item quantity instead of item weight. Item quantity can be modified by the scale operator.





To enter Non-Weight Item Mode and work with a non-weight product not stored in the scale memory, do the following:

- Make sure that the platter/pan is empty;
- If the display tag **ZERO** is off, press the key  – the tag **ZERO** will turn on;
- Key in unit price (refer to paragraph 2.2 Unit Price);
- Press the key . The scale will display quantity of a product in pieces instead of its weight (by default



the quantity equals to “1”);

- The display tag **PCS** will turn on confirming that the scale is in Quantity Editing Submode;
- Using the numeric keys   enter the quantity of a non-weight product;
- To change unit price, again press the key : the display tag **PCS** will turn off confirming that it is possible to enter a new unit price with the numeric keys. In Non-Weight Item Mode the key  is used to switch between Quantity Editing and Price Editing Submodes;
- To quit Non-Weight Item Mode, press the key .

The scale automatically enters Non-Weight Item Mode and the display tag **PLU** turns on, once a non-weight item preset in the PLU memory of the scale is selected (refer to paragraph 2.1 Selecting Items). To enter quantity and override unit price values, use numeric keys  . The key  switches between Quantity Editing and Price Editing Submodes. Unit price overriding can be disabled by the system administrator. To automatically quit Non-Weight Item Mode, discard the selected item by pressing the key .

## 2.5 Printing Labels

The scale allows to print several types of labels. Standard label is used for labeling products that are being packed in store or have already been prepackaged (refer to paragraph 2.5.1 Standard Labels). Grand totals label contains information accumulated in the grand totals memory (refer to paragraph 2.7 Grand Totals Memory).

### 2.5.1 Standard Labels

To print a standard label, use the key . Textual and graphic information printed on a standard label, as well as its arrangement are programmed by the system administrator.

**Important!** In all scale models except for SHTRIH-PRINT PV design, as a label has been printed and fed out of the printer, it is recommended to remove it with a hand movement from right to left rather than pulling it or detaching it in the direction from left to right. In SHTRIH-PRINT PV model, due to a different mechanism, as a label has been printed and fed out of the printer, it is recommended to remove it by pulling the label towards the operator. These methods provide the easiest and smoothest way of removing printed labels.

**Important!** Always control the quality of printed labels containing data like weight, unit price, product cost, and a bar code. The black and white stripes of a bar code must be clear, sharp, and without defects. Otherwise contact the system administrator. If the bar code integrity control line is enabled by the system administrator, always make sure that this line above the bar code is solid, without gaps and white dots, otherwise report to the system administrator.

To print a label, several conditions must be fulfilled:

1. The calculated cost must be greater than zero.  
Operating with a weight item: the cost will be calculated, if the display tag **FIX** is on. It means that the weight on the platter/pan has been measured, its value is within Min and Max, and the unit price has been set.  
Operating with a non-weight item: quantity and unit price must be set.
2. If a label is to be printed for a weight item in the automatic mode, the weight value of the product should be greater than the autoprinting threshold. Refer to paragraph 2.6. Automatic Label Printing for details.

3. Label paper must be properly loaded in the printing mechanism; label format should match the one selected by the system administrator (refer to paragraph 1.7 Loading Paper in Printing Mechanism). If printing is done on labels smaller than the label size configured in the scale settings, the scale will display a warning message “Incomplete printing!”. The description of other printing errors and their troubleshooting are given in paragraph 3.3 Printing Errors.
4. The system administrator can enable the label stripping sensor. If the last printed label has not been removed, the printing of the next label does not commence, the scale emits an error beep and displays a message “Remove the label!”.
5. Label printing function can be disabled by the system administrator. If label printing is disabled, the scale emits an error beep and displays a message “Settings error 115”.







If automatic label printing is enabled (the display tag **AUTO** is on), a standard label is printed automatically upon placing a product on the weigh platter/pan. The system administrator can additionally enable Print Label if PLU Chosen function. For a detailed information on the automatic label printing function refer to paragraph 2.6. Automatic Label Printing.

NOTE 1. Standard label of a non-weight item differs from a standard label of a weight item only in having quantity in pieces instead of weight in kilograms.

NOTE 2. If enabled by the system administrator, pressing the key  can print a standard label and simultaneously add a sales transaction to the grand totals (GT) memory.

## 2.5.2 Label Copies for Non-Weight Items

To print several label copies for a non-weight item (up to 99), follow the procedure below (provided that a non-weight item has been selected or the scale is in Non-Weight Item Mode):

- Press the key . Then enter the required number of copies with the numeric keys  ..  and press one of the keys  or ;
- To print only one copy of the last non-weight item label, instead of the actions described above simply double-press the key  without entering the number of copies;
- The system administrator can enable label stripping sensor. In this case, the scale does not print the next label until the last printed label has been removed. Otherwise, the scale will print labels without checking if they are being removed or not. This option can be used only if the take-up unit is disabled, the liner is not wound on it, and the label paper is fed out of the printer;
- The scale emits short periodic beeps while waiting for the printed label to be removed.

## 2.6. Automatic Label Printing

Automatic label printing function facilitates the printing of standard labels (refer to paragraph 2.5.1 Standard Labels). The turned on display tag **AUTO** demonstrates that the automatic label printing function is enabled.

Automatic label printing is related to the autoprinting threshold parameter which value can be adjusted (refer to paragraph 2.9.5 Autoprinting Threshold). Autoprinting threshold of the automatic printing is a weight value set for specific labeling tasks by an operator or the system administrator (exact values depend on the type of the product being weighed and its tare parameters). A label is printed, if the measured net weight of an item placed on the platter/pan exceeds the programmed autoprinting threshold weight value. A properly set threshold value allows operators to use tare weight value measured on the scale for automatic printing (refer to paragraph 2.3.1 Measuring

Unknown Tare Weight on Scale).

To use the automatic printing function, always select an item or set unit price first, and then place the product on the weigh platter/pan. It is redundant to use the key  for automatic label printing. As soon as the net weight has been measured and product cost has been calculated, a label is printed, provided that the measured net weight exceeds the autoprinting threshold value. Other conditions that can block automatic label printing are described in paragraph 2.5.1 Standard Labels.

It is possible to use automatic printing in the reversed order – place a product on the platter/pan first and then select an item or set unit price – in case Print Label if PLU Chosen function is enabled by the system administrator.

To use the automatic printing function recurrently, remove the product from the platter/pan together with the tare (if tare is used).

**Important!** It is not recommended to use automatic label printing function when products are placed on the platter/pan or into the tare by pieces or filled up by portions, since label printing is triggered immediately after the threshold weight value has been exceeded. On the other hand, autoprinting threshold can be intentionally used for packing such products with target weight.

**Important!** In autoprinting, if tare weight can be greater than the weight of a product, it is recommended to enter tare weight value first and only then enable the Automatic Label Printing function.



**Important!** If Prepacking Mode is enabled, Automatic Label Printing function is operating differently from the described above (refer to paragraph 2.8 Prepacking Mode).

## 2.7 Grand Totals Memory

The grand totals memory (GT memory) allows to calculate the total sales amount of miscellaneous items (if Prepacking Mode is off; refer to paragraph 2.8 Prepacking Mode for details) or the total weight/quantity of one item (if Prepacking Mode is on). The turned on display tag **M** shows that the grand totals memory is not empty. The accumulation in the grand totals memory continues until the grand totals sales amount reaches its maximum value of “9999.99” (or “999999”, if the decimal separator is not used), the quantity of grand totals transactions – “255”, and the grand totals weight – “65.535” kg (in Prepacking Mode).

### 2.7.1 Add to Grand Totals Memory

To add transaction cost (as well as weight/quantity in Prepacking Mode) of an item to the grand totals memory, do the following:

- Press the key .
- After the first transaction has been added to the GT memory, the display tag **M** turns on showing that the GT memory is not empty;
- In the second line of the display, the scale will indicate a message “Grand totals:” along with the sales amount (as well as weight/quantity in Prepacking Mode) accumulated in the GT memory inclusive of the latest transaction;
- Pressing the key  or changing the weight on the platter/pan (e.g. by taking the item off the load receptor) will interrupt the indication of the contents of the GT memory.

**Important!** The system administrator can program the scale to print a standard label and simultaneously add a



transaction to the grand totals memory by pressing the key . For details refer to paragraph 2.5.1 Standard Labels.

## 2.7.2 Void from Grand Totals Memory

Press the key  to void the last transaction added to the grand totals memory: the scale will display a message “Transaction voided!” for several seconds. It is possible to void the last transaction only. In case of an attempt to void any other transactions added to the GT memory earlier, the scale will emit an error beep and display a message “Can't void transaction”. If the voided transaction was the only one accumulated in the grand totals memory, the display tag **M** will turn off meaning that the GT memory is empty.

## 2.7.3 Grand Totals Mode and Grand Totals Labels

To enter Grand Totals Mode, press the key . The scale will indicate the grand totals sales amount (as well as grand totals weight/quantity, if Prepacking Mode is on) and number of grand totals transactions. The following options are available for the scale operator at this point:

- To continue adding transactions to the GT memory, press the key . The contents of the GT memory will remain intact, and the scale will return to the normal operating mode;
- To clear the accumulation in the GT memory, press the key . The contents of the GT memory will be cleared, the display tag **M** will turn off, and the scale will return to the normal operating mode;
- To print a grand totals label containing the GT sales amount (as well as grand totals weight/quantity, if Prepacking Mode is on), press the key . The GT label will be printed, the contents of the GT memory will be cleared, the display tag **M** will turn off, and the scale will return to the normal operating mode.

NOTE. To print a label with the GT sales amount and its equivalent in the secondary currency, activate Secondary Currency Equivalent Mode before entering Grand Totals Mode (refer to paragraph 2.9.7 Secondary Currency Cost Equivalent). The sales amount will be printed on a label in both currencies, if the printing of the secondary currency cost equivalent is enabled by the system administrator in the selected label format.





A grand totals label will be successfully printed under the following conditions:



- Label paper must be properly loaded in the printing mechanism; label format should match the one selected by the system administrator (refer to paragraph 1.7 Loading Paper in Printing Mechanism). If printing is done on labels smaller than the label size configured in the scale settings, the scale will display a warning message “Incomplete printing!”. The description of other printing errors and their troubleshooting are given in paragraph 3.3 Printing Errors;
- The system administrator can enable label stripping sensor. If the last printed label has not been removed, the printing of the next label does not commence, the scale emits an error beep and displays a message “Remove the label!” while still in Grand Totals Mode;
- Label printing function can be disabled by the system administrator. If label printing is disabled, the scale emits an error beep and displays a message “Settings error 115”.

It is impossible to enter Grand Totals Mode, if the GT memory is empty (i.e. when the display tag **M** is off).

## 2.7.4 Change Calculation

To calculate change amount due to a customer with several transactions added to the GT memory (refer to paragraph 2.7.1 Add to Grand Totals Memory), press the key . The scale will enter Change Calculation Mode and display the grand totals sales amount and number of transactions. The following options are available for the scale operator at this point:

- To continue adding transactions to the GT memory, press the key . The contents of the GT memory will remain intact, and the scale will return to the normal operating mode;
- To calculate the change, enter the amount received from the customer with the numeric keys   and press the key . The scale will display the calculated change amount.

If the amount received from the client was entered correctly and it is not necessary to continue adding transactions to the GT memory, press the key . The contents of the GT memory will be cleared, the display tag **M** will turn off, and the scale will return to the normal operating mode. To edit the entered amount received from the client, press the key  and enter the received amount again.

## 2.8 Prepacking Mode

Prepacking Mode is designed for processing one item and printing standard and grand totals labels. Prepacking Mode can be enabled either by the system administrator or with a properly programmed quick access key (refer to paragraph 1.3 Quick Access Keypad). When the scale is in Prepacking Mode, the display indicator **PACKING** is on (refer to paragraph 1.5 Display).

Prepacking Mode is different from the normal mode in the way how the grand totals memory and the automatic label printing functions operate in it. These differences provide for a faster and easier packing of an item as well as for printing not only standard labels, but also grand totals labels with the total net weight of a one-pack. It is not recommended to use Prepacking Mode for any other tasks.

Differences of the operation of the grand totals memory in Prepacking Mode:

- It is not allowed to discard item selection, to select another item, or to change item unit price – it can be done only after the accumulation to the GT memory has been finished and its contents has been cleared;
- It is not allowed to use quick access keys since they can be programmed to call up items or unit price values, or to modify scale parameters that influence scale operation – it can be done only after the accumulation to the GT memory has been finished and its contents has been cleared;
- When adding transactions to the grand totals memory, item selection, even though enabled by the system administrator, cannot be automatically discarded – it will be done only after the accumulation to the GT memory has been finished and its contents has been cleared;
- The grand totals memory accumulates not only transaction cost amounts, but also the net weight/quantity of the item;
- A transaction will be added to the grand totals memory, even if the calculated cost is "0" (item unit price can be undefined);
- The grand totals label will contain the accumulated value of the grand totals net weight.

Differences of the operation of the automatic label printing in Prepacking Mode:

- Every automatically printed label adds the measured net weight and the calculated cost to the GT

memory;

- The scale can simultaneously print a label and add a transaction cost to the GT memory, only if this option is enabled by the system administrator.

The operation of grand totals memory and the automatic label printing functions is described in details in paragraphs 2.7 Grand Totals Memory and 2.6. Automatic Label Printing.





## 2.9 Additional Functions

Access to the most additional functions of the scale can be programmed by the system administrator with the help of quick access keys (refer to paragraph 1.3 Quick Access Keypad). Any scale operator can always change PLU and price presets of quick access keys. Saving item price to the PLU memory of the scale can be disabled by the system administrator.

### 2.9.1 Programming of Quick Access Keys

Programming of Quick Access Keys is an easy and convenient function allowing any scale operator to configure quick access keys (refer to paragraph 1.3 Quick Access Keypad) to call up PLUs and unit price presets (assistance of the system administrator is not required).





To program a quick access key to call up an item (PLU) or a unit price from the scale memory, follow the procedure:

- Choose an item you would like to call up with a quick access key (refer to paragraph 2.1 Selecting Items), or enter the required unit price (refer to paragraph 2.2 Unit Price);
- If the display tag **REG** is on, turn it off with the key ;
- Press the key  – the scale will display a message “Set key to call item” (if an item has been selected), or a message “Set key to call price” (if item unit price has been entered);
- Depending on the number of the quick access key to be programmed, it may be necessary to turn on the display tag **REG** with the key  (for details refer to paragraph 1.3 Quick Access Keypad);
- Press the quick access key you would like to program – the scale will return to Main Mode. To quit programming of quick access keys without saving any presets, press the key  instead of the quick access key.

### 2.9.2 Saving Unit Price to Scale PLU Memory

It may be useful to have an opportunity to save a new unit price of an item to the PLU memory of the scale, if the unit price has changed in the back-office software, but the system administrator has not been able to update item information in the scale. If an operator has overridden the unit price of an item with the numeric keys (refer to paragraph 2.1.4 Overriding Unit Price of Selected Item), the new unit price is not automatically saved to the PLU memory of the scale. To save the unit price change to the PLU memory, follow the procedure (provided that an item has been selected and its new unit price value has been entered):

- If the display tag **REG** is off, turn it on with the key ;

- Press the key  – the scale will display a message “Save price to PLU”;
- Press the key  to store the new item unit price to the PLU memory of the scale; the scale will return to Main Mode. To abort saving the new unit price to the PLU memory of the scale, press the key  instead of pressing the key .

The function of saving unit price changes to the PLU memory of the scale can be disabled by the system administrator.

### 2.9.3 Date

The scale has a built-in real-time clock. Date and time values can be printed on labels and used to calculate item expiration date by the preset item shelf life. Do not fail to program current time and date values.

To enter Date Program Mode, press a corresponding quick access key (contact the system administrator) – the scale will return the current date value in the second line of the display as in [Illustration 16](#) below:

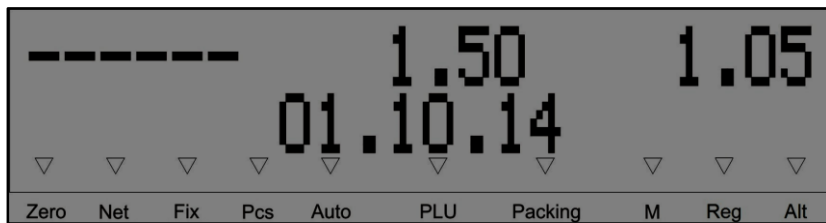







Illustration 16

To enter a new date value, use the numeric keys  . Upon pressing a numeric key, the digit being edited will be highlighted by the blinking cursor. To edit the next digit, press the key . To complete setting a new date value, press the key . If the scale emits a long beep, the new date value is invalid (for example, the month value is greater than “12”). To quit Date Program Mode without saving the changes, press the key .

### 2.9.4 Time

The scale has a built-in real-time clock. Date and time values can be printed on labels and used to calculate item expiration date by the preset item shelf life. Do not fail to program current time and date values.

To enter Time Program Mode, press a corresponding quick access key (contact the system administrator) – the scale will return the current time value in the second line of the display as in [Illustration 17](#) below:

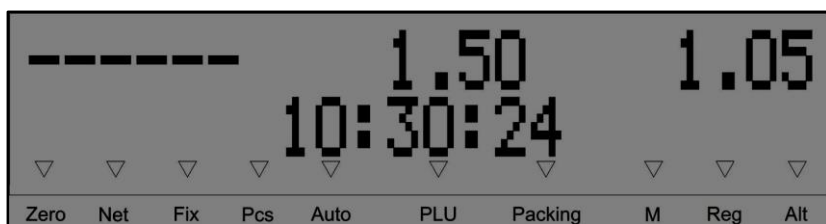

Illustration 17

To enter a new time value, use the numeric keys **0**..**9**. Upon pressing a numeric key, the digit being edited will be highlighted by the blinking cursor. To edit the next digit, press the key **→**. To complete setting a new time value, press the key **←**. If the scale emits a long beep, the new time value is invalid (for example, the minutes value is greater than “60”). To quit Time Program Mode without saving the changes, press the key **↺**.

NOTE. If time is set in the 12-hour format, use quick access keys with Latin characters “A” and “P” to select between “AM” and “PM”.

## 2.9.5 Autoprinting Threshold

Autoprinting threshold is a parameter that regulates the operation of the automatic label printing function (for details refer to paragraph 2.6. Automatic Label Printing).

To enter Autoprinting Threshold Program Mode, press a corresponding quick access key (contact the system administrator) – the scale will return the current value of the autoprinting threshold in the second line of the display as in [Illustration 18](#) below:



Illustration 18

To enter a new value of the autoprinting threshold, use the numeric keys **0**..**9**. To complete setting a new autoprinting threshold value, press the key **←**. If the scale emits a long beep, the new value of the autoprinting threshold is invalid (for example, it exceeds Max). To quit Autoprinting Threshold Program Mode without saving the changes, press the key **↺**.

Automatic label printing function can be disabled by the system administrator. In this case, the scale will emit an error beep and display a message “Autoprinting disabled!” to an attempt to change the autoprinting threshold value.

NOTE 1. If the autoprinting threshold value is programmed to be “0”, the display tag **AUTO** will turn off and the automatic label printing function will be disabled. Other values of the autoprinting threshold enable the automatic label printing function and turn on the display tag **AUTO**.

NOTE 2. It is not recommended to set the value of the autoprinting threshold smaller than Min, since the scale prints a label, only if the net weight of an item exceeds Min. Min and Max values are indicated on the special sticker under the display.

## 2.9.6 Currency Exchange Rate

Currency exchange rate indicates how many units of the primary currency (Euro) correspond to one unit of the secondary currency. By programming this parameter, it will be possible to request the cost of a product in the both currencies (refer to paragraph 2.9.7 Secondary Currency Cost Equivalent). Secondary currency cost equivalent is not available, if the currency exchange rate is not set (equals to “0”).



To enter Currency Exchange Rate Program Mode, press a corresponding quick access key (contact the system administrator) – the scale will return the current value of the currency exchange rate in the second line of the display as in [Illustration 19](#) below:

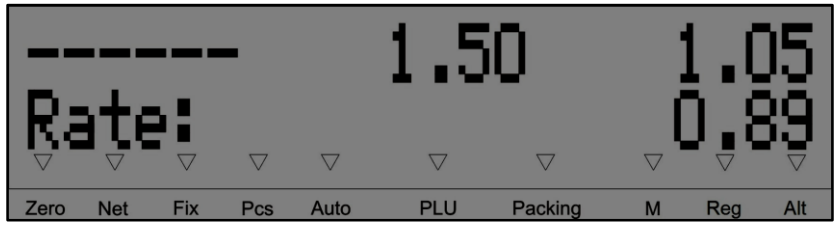

Illustration 19

To enter a new value of the currency exchange rate, use the numeric keys **0**..**9**. To complete setting a new currency exchange rate value, press the key **←**. To quit Currency Exchange Rate Program Mode without saving the changes, press the key **↺**.

### 2.9.7 Secondary Currency Cost Equivalent

Secondary currency cost equivalent is a helpful option allowing operators to view the equivalent cost of an item in the secondary currency calculated by the preset currency exchange rate (refer to paragraph 2.9.6 Currency Exchange Rate). Access to Secondary Currency Cost Equivalent Display Mode is denied, if the exchange rate value is not set (equals to "0"): the scale emits an error beep and displays a message "Exchange rate not set!".

To enter Secondary Currency Cost Equivalent Display Mode, make sure that the cost of an item has been calculated. Press a corresponding quick access key (contact the system administrator) – the scale will return the cost value of the item in the primary currency and its equivalent in the secondary currency in the second line of the display as in [Illustration 20](#) below:

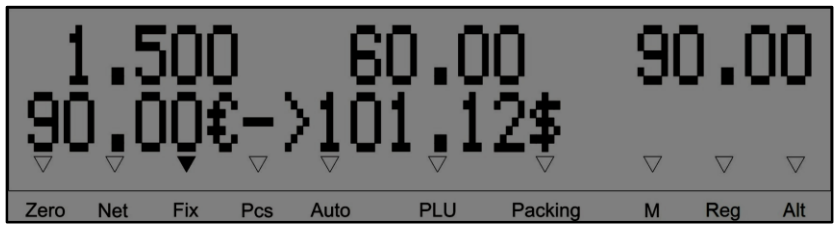

Illustration 20

If a standard label is printed in Secondary Currency Cost Equivalent Display Mode, the printed label will contain the cost in the primary and in the secondary currencies, if the printing of the secondary currency cost equivalent is enabled by the system administrator in the selected label format.

To quit Additional Currency Cost Equivalent Display Mode, press a corresponding quick access key (contact the system administrator). Quick access keys for entering and quitting this mode should be different (one key cannot perform the both functions).

### 2.9.8 Production Date

Item production date is used to calculate item expiration date. Expiration date is reckoned from the production date by adding to it the item shelf life set in days. If item production date is undefined, it is taken to be equal to the

current date from the internal real-time clock. Item production date can be programmed in PLU data, and it will be automatically used to calculate item expiration date.

It is possible to enter a new production date for an item, if it is undefined or if it needs to be modified. Press a corresponding quick access key (contact the system administrator) – in the second line of the display the scale will return the current item production date or dashes “--.--.--”, if the production date is undefined as in [Illustration 21](#) below:



Illustration 21

To enter a new item production date, use the numeric keys **0**..**9**. Upon pressing a numeric key, the digit being edited will be highlighted by the blinking cursor. To edit the next digit, press the key **→**. To complete setting a new item production date value, press the key **↩**. If the scale emits a long beep, the new item production date value is invalid (for example, the month value is greater than “12”). To quit Item Production Date Program Mode without saving the changes, press the key **↺**.

To clear the defined earlier item production date, press the key **C** when in Item Production Date Program Mode. The scale will display dashes instead of the production date value. Confirm the clearing of the item production date with the key **↩**. The scale will then use the current date from internal real-time clock as the item production date.

If the production date is programmed in the PLU data of an item, it will be automatically selected when this item is called up, and the production date entered manually earlier will be discarded. If there is no production date programmed in the PLU data of an item, the production date entered manually before will be valid for that item. Deselecting an item will discard item production date regardless of how it was set – manually or automatically by selected an item.

### 2.9.9 Arbitrary Bar Code

Often retailers need to relabel products arrived from vendors, or to print a bar code with a structure different from that programmed in the scale. Arbitrary bar code printing function is designed for these tasks. An arbitrary bar code can be set only when an item is selected (the display tag **PLU** is on). Press a corresponding quick access key (contact the system administrator) – in the second line of the display the scale will indicate an invitation to input the first 12 digits of the bar code to be printed, as in [Illustration 22](#) below:

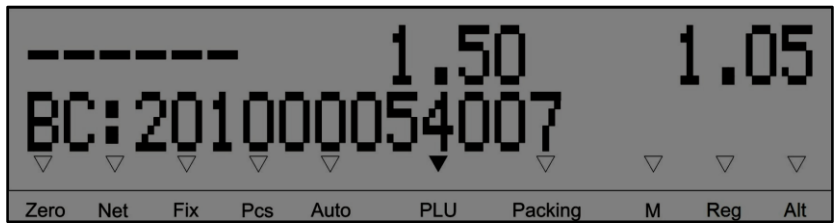

Illustration 22

To enter the first 12 digits of an arbitrary bar code (BC), use the numeric keys **0**..**9**. The last digit of the BC will be automatically calculated by the scale. Use the key **C** to delete the last entered digit, if the blinking cursor is in the end in the line. Move the cursor to the left and to the right with the keys **←** and **→** and edit the digit highlighted by the blinking cursor with numeric keys. Keeping the key **C** pressed clears all digits of the arbitrary bar code. To confirm setting an arbitrary bar code value, press the key **↵**. To quit Arbitrary Bar Code Input Mode without saving the changes, press the key **↻**.

It is possible to input the value of the arbitrary bar code from the bar code scanner connected to the scale. In Arbitrary Bar Code Input Mode, read the sample bar code with the scanner instead of entering its digits with numeric keys. Depending on the settings of the scanner, it will read the sample bar code immediately upon pointing the laser beam at it or after pressing the scan button on the scanner. Contact the system administrator to check how exactly your scanner is programmed to operate. The sample bar code transmitted to the scale (its first 12 digits) will be indicated in the second line of the display of the scale.

The entered arbitrary bar code can be used as long as an item is selected. Deselecting an item will discard the entered arbitrary bar code. The arbitrary bar code is not stored in the PLU data of an item, so selecting an item with an arbitrary bar code was entered sometime before will not automatically call up that arbitrary bar code, and the scale will print bar codes formed according to the structure programmed in its settings.

**2.9.10 Other Additional Functions**

Quick access keys (refer to paragraph 1.3 Quick Access Keypad) can be programmed by the system administrator to execute other functions, e.g. to adjust the print contrast, to change the media type (label paper or receipt paper), to enable/disable label stripping sensor, change label format, turn on/off Prepacking Mode, etc. When executing some of these functions that modify scale parameters (e.g. print contrast or label format), the scale does not display any messages, thus to control the results of executing these functions it is required to perform a corresponding action (for the example given above – to print a label and check its contrast and format).

Contact the system administrator to learn how quick access keys are programmed. Default value for all quick access keys is the same – “No functions”.

**2.10 Advertisement Text**

The system administrator can enable the automatic displaying of the advertisement text. If an operator has not been performing any actions with the scale for 5 minutes (i.e. has not been weighing products or pressing any keys), the scale will show in the lower line of the display a scrolling text programmed by the system administrator. Pressing any key or changing the weight on the platter/pan will automatically turn off Advertisement Text Mode.

## 2.11 Functions Remotely Controlled by System Administrator

In Main Mode some of the functions can be remotely performed by the system administrator from the PC. Scale operators are informed about these actions with messages displayed by the scale. Urgent message is a specially designed function to instantly transmit a short message from the system administrator to the operator.

### 2.11.1 Clear DB/Sales Records

The system administrator can enable a mode to clear sales records and the internal memory of the scale containing PLUs and messages (database). In Clear DB/Sales Records Mode the operation of the scale is blocked, and the scale displays a message as in [Illustration 23](#) below:



Illustration 23

Wait for the scale to return to normal operating mode. Remember that having deleted all PLU data and messages, it will be impossible to call up items (refer to paragraph 2.1 Selecting Items) until new PLUs and messages are loaded to the scale.

### 2.11.2 Quick DB Update Mode

The system administrator can enable the mode of fast loading of PLUs and messages to the internal memory of the scale. In Quick DB Update Mode the operation of the scale is locked, and the scale displays a message as in [Illustration 24](#) below:

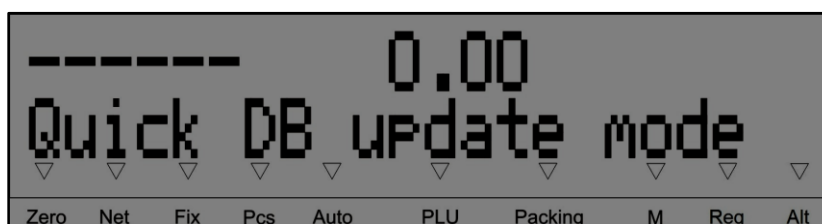



Illustration 24

If it is not necessary to weigh or label products, when quick DB update is in progress, it is recommended to wait for the update to complete, because it takes no longer than 1.5 minutes (time given for an update via Ethernet network not overloaded with third-party traffic, if PLUs and messages are loaded in blocks). The scale will return to the normal operating mode, when the loading is finished. If there is no opportunity to wait for the loading to complete, an operator can quit Quick DB Update Mode by pressing the key . The scale will return to the normal operating mode, and the DB update will continue at the standard speed. Standard speed update takes longer time to update the DB, but loading will not interfere with the operation of the scale.

**Important!** It should be noted that when the DB is being updated, PLU data can change significantly, e.g. unit price, shelf life, etc. can change. It may occur that a different item will be recorded to a certain PLU unit. Always contact the

system administrator to check how exactly the DB has been updated and what has changed.

### 2.11.3 Selected PLU Update Warning

If an item is selected (the display tag **PLU** is on) and the system administrator has updated PLU data of this item in the DB of the scale, the scale will automatically update the data of the selected item on the display, show a message "Item has been changed!", and emit an error beep, so that a scale operator could notice that data of the selected item (name, unit price, code, etc.) may have changed. If this occurs, contact the system administrator to know what data of the selected item has been modified.

### 2.11.4 Urgent Message

This function is specially designed to instantly transmit a short message from the system administrator to the operator and show it on the display of the scale. The urgent message is displayed immediately as received by the scale. The urgent message does not interfere with the actions of the operator performed before its arrival. Please find an example of an urgent message in [Illustration 25](#) below:



Illustration 25

Press any key to clear the urgent message from the display. The scale will return to the mode before the arrival of the urgent message.

## Part 3. Errors and Troubleshooting

In case of any troubles and errors, check this section before contacting the system administrator or the service support center – perhaps, the problem can be easily resolved. All errors are arranged in tables and divided into 3 main groups for their easier location: Power-Up Errors, Main Mode Errors, and Printing Errors. Each table consists of the following columns:

- “Message” column contains the message displayed by the scale, if an error occurs;
- “Description” column contains a short explanation of the problem;
- “Troubleshooting” column contains recommendations to be undertaken to resolve the problem.

If neither this section nor the system administrator or your service support center have managed to resolve your problem, you can address the Service Support Team of SHTRIH-M Company based in Moscow, Russia:

- Working hours – 10.00 to 19.00 Moscow time (07.00 to 16.00 UTC);
- Tel.: +7 (495) 787-6090;
- Fax: +7 (495) 787-6099;
- E-mail: support@shtrih-m.ru;
- Web: www.shtrih-m.ru.

### 3.1 Power-Up Errors

The scale runs a self-test at power-up. If the unit is improperly installed, out of order, etc., and the self-test detects this, the scale will display information about the detected errors after all power-up procedures described in paragraph 1.6 Scale Power-Up. There are also several errors not related to the unit self-test. In **Table 1** in Error Type column they are marked with the tag “—” (not self-test) and the rules described in paragraphs 3.1.1 – 3.1.4 do not apply to them. If such errors make further operation of the scale impossible, they are marked with the tag “—/B” (not self-test, operation blocked).

#### 3.1.1 Single Power-Up Error

If the power-up self-test detects a single error, its message will be displayed by the scale after the power-up procedure. The first line of the display will contain a message disclosing the nature of the error, and the second line will contain an instruction to press the key  to continue operation of the scale, like in [Illustration 26](#) below:



Illustration 26

The scale then proceeds with displaying troubleshooting recommendations (refer to paragraph 3.1.4 Troubleshooting Recommendations Display Mode). A complete list of power-up errors and their troubleshooting is given in **Table 1** below.

### 3.1.2 Multiple Power-Up Errors

A situation may occur, when the power-up self-test detects several errors. In this case, the scale will display a warning about multiple errors as in [Illustration 27](#) below:

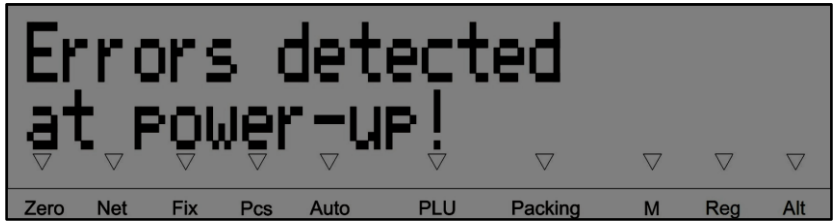



Illustration 27

After this warning the scale will display an invitation to view the list of detected errors or to skip this, as in [Illustration 28](#) below:



Illustration 28

To view the list of detected errors, press the key . After the list of detected errors, the scale will display their troubleshooting recommendations. To skip viewing the list of detected errors, press the key : the scale will proceed with displaying troubleshooting recommendations (refer to paragraph 3.1.4 Troubleshooting Recommendations Display Mode). A complete list of power-up errors and their troubleshooting is given in **Table 1** below.

### 3.1.3 Errors List Viewing Mode

In Errors List Viewing Mode, the most critical error is indicated on the display of the scale as in [Illustration 29](#) below:

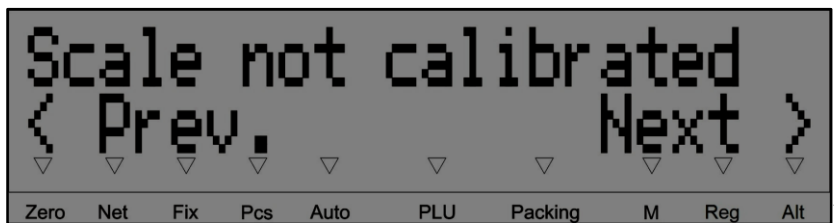







Illustration 29

To view other errors, use the keys  and . To quit Errors List Viewing Mode, press any of the following keys: , , or . The scale will then proceed with displaying troubleshooting recommendations (refer to

paragraph 3.1.4 Troubleshooting Recommendations Display Mode).

### 3.1.4 Troubleshooting Recommendations Display Mode

Having displayed information about single or multiple errors, the self-test may recommend the following troubleshooting scenarios depending on how critical the errors are:

1. Block further operation of the scale and recommend switching it off (in Error Type column of **Table 1** such errors are marked with the tag “**B**” [blocked]);
2. Recommend entering the Service Menu, and if the operator fails to do so – block the scale and recommend switching it off (in Error Type column of **Table 1** such errors are marked with the tag “**S/B**” [Service Menu or blocked]);
3. Recommend entering the System Menu, and if the operator fails to do so or if the system administrator does not take recommended actions in the System Menu – go to Main Mode, but certain functions will not be available (in Error Type column of **Table 1** such errors are marked with the tag “**M/R**” [System Menu or restrictions]);
4. Disable certain functions, display a warning about such restrictions (see [Illustration 30](#) below), and go to Main Mode (in Error Type column of **Table 1** such errors are marked with the tag “**R**” [restrictions]);
5. Recommend setting date and time, and having done that – go to Main Mode (in Error Type column of **Table 1** such errors are marked with the tag “**DT**” [set date and time]).



Illustration 30

For an operator the first two scenarios require assistance from the system administrator. An operator may continue work in Scenarios 3 (by refusing to enter the System Menu and pressing the key ) and 4, if the restrictions allow that. In Scenario 5, an operator should simply enter current date and time, but if such errors occur on every power-up of the scale, report it to the system administrator (refer to paragraphs 2.9.3 Date and 2.9.4 Time).

### 3.1.5 Power-Up Errors

Table 1

Message	Error Type	Description	Troubleshooting
No message displayed	—/B	No sound signals at power-up, the display is off.	Make sure that the electrical network is operating properly, the power switch of the scale is on, otherwise contact the system administrator.



Message	Error Type	Description	Troubleshooting
No message displayed / SHTRIH-PRINT DISPLAY SM807.31. v.1.2 XXX	—/B	The display is off, or the display is on with the indicated message. Repeating error beep. The scale would not enter Main Mode, does not respond to keys pressed. "XXX" stands for the supported code page.	Contact the system administrator.
SHTRIH-PRINT Loader Status: CRC error!	—/B	The scale would not enter Main Mode, does not respond to keys pressed.	Scale firmware update is required. Contact the system administrator.
SHTRIH-PRINT Loader Status: button pressed	—/B	The scale would not enter Main Mode, does not respond to keys pressed.	Possible scale keyboard failure. Contact the system administrator.
RTC error!	R	Internal real-time clock failure.	Label printing and sales recording are disabled.
WDT error!	B	The scale detected restart by the built-in watchdog timer.	Turn the scale off and then on again. If the error remains, contact the system administrator.
WM100 not found!	R	The weigh module of the scale has not been detected and can be out of order.	Weighing is disabled. Operation only in Non-Weight Mode.
WM100 CS is unknown!	R	The checksum of the metrologically relevant part of the scale firmware has not been identified.	Contact the system administrator.
Scale not calibrated!	S/B	The scale is not calibrated.	Contact the system administrator.
Serial number not set!	S/B	The serial number of the scale is not set.	Contact the system administrator.
Invalid password!	—	Error returned to an attempt to enter the Service/System Menu.	Depending on the status of the error that suggested entering the menu, operation of the scale will be either continued (in Main Mode) or blocked.
Date/time not set!	DT	Date and time are not set in the internal real-time clock of the scale.	After displaying the error, the scale will enter Date Program Mode and Time Program Mode. Enter current date and time (refer to paragraphs 2.9.3 Date and 2.9.4 Time).
Currency sign error!	R	Currency signs have not been loaded to the scale display.	In Secondary Currency Cost Equivalent Mode currency signs will not be displayed or will be displayed improperly. Report the error to the system administrator.
CS8900 not found!	R	Ethernet interface system error.	Ethernet interface of the scale will be disabled, it may not be possible to update PLU, messages, etc. from the back-office software. Report the error to the system administrator.
DB structure error!	M/R	Invalid structure of the PLU database.	Contact the system administrator.
SRAM not initialized!	M/R	Internal memory of the scale has not been initialized.	Contact the system administrator.

Message	Error Type	Description	Troubleshooting
ADC error!	R	The analogue-to-digital converter of the weigh module is out of order.	Weighing is disabled. Operation only in Non-weight Mode. Report the error to the system administrator.
Scale overloaded!	R	The load on the platter/pan exceeds Max, or the scale needs to be calibrated.	The platter/pan should be empty on power-up. Otherwise, remove the load from the platter/pan. If the display tag <b>ZERO</b> would not turn on, contact the system administrator.
Weight not stable!	R	The platter/pan of the scale is not stable on power-up.	Make sure that the platter/pan is properly installed and is not influenced by any foreign objects or strong air flows. If the display tag <b>ZERO</b> would not turn on, contact the system administrator.
Zero range error!	R	There is load remaining on the platter/pan; the scale needs to be calibrated; possible weigh module failure.	The platter/pan should be empty on power-up. Otherwise, remove the load from the platter/pan. If the display tag <b>ZERO</b> would not turn on, contact the system administrator.
Zero not set!	R	There is load remaining on the platter/pan; it is impossible to set the weight value to zero.	The platter/pan should be empty on power-up. Otherwise, remove the load from the platter/pan. If the display tag <b>ZERO</b> would not turn on, contact the system administrator.
System error!	R	Error occurred while setting the weight value to zero at power-up.	Contact the system administrator.
Printing interrupted. Repeat operation.	—	The power failure occurred while printing a label with the enabled sales recording function.	Print a label again. The previous transaction was not stored in the sales records.
Incomplete operation has been found!	—	The power failure occurred while printing a label with the enabled sales recording function.	To complete the sales record transaction, press any key. If the scale displays a message "Error XXX" after that, report the error to the system administrator.

### 3.2 Main Mode Errors

Table 2

Message	Description	Troubleshooting
The scale returns a short double-beep error sound to any key pressed, the message "Keyboard locked!" is indicated in the second line of the display.	The keyboard of the scale has been locked.	To unlock the keyboard, press the key  .



Message	Description	Troubleshooting
The scale emits a short double-beep error sound, when the keys for operation with the grand totals memory (  ,  ,  ,  ) or the key  are pressed.	These functional keys are blocked by the system administrator.	Contact the system administrator.
The scale emits a normal short confirmation signal, when a quick access key is pressed, but nothing happens.	Any quick access key can be programmed to perform a certain function as well as to perform no functions at all.	Check the function of the quick access key with the system administrator.
The scale emits a long error beep, when a key of the Numeric and Functional keypad is pressed.	The key is pressed in a mode, in which it is not used.	Check the operation of the scale according to this guide, or contact the system administrator.
The scale displays dashes in the weight indicator and emits error beeps. The second line of the display contains a message "Scale overloaded!".	The scale is overloaded.	The weight on the platter/pan exceeds Max. Repeat the weighing of the load not exceeding Max. Max value for the scale is indicated on a special sticker under the display.
The scale displays dashes in the cost indicator and emits error beeps. The second line of the display contains a message "Cost out of range!".	The cost value is too big.	Item cost value cannot exceed "9999.99" (or "999999", if the decimal separator is to used).
GT Memory not empty!	Returned to an attempt to select another item in Prepacking Mode with transactions in the GT memory.	These operations are not available in Prepacking Mode and with the GT memory containing transactions (when display tags <b>PACKING</b> and <b>M</b> are on). Clear the GT memory (refer to paragraphs 2.7.3 Grand Totals Mode and Grand Totals Labels and 2.7.4 Change Calculation).
	Returned to an attempt to discard item selection by pressing the key  (as well as keeping it pressed) or  in Prepacking Mode with transactions in the GT memory.	
	Returned to an attempt to enter Non-Weight Item Mode with no items selected in Prepacking Mode with transactions in the GT memory.	
	Returned to an attempt to use quick access keys.	
	Returned to an attempt to enter System Menu with transactions in the GT memory.	
GT Memory is empty!	Returned to an attempt to enter Grand Totals Mode or Change Calculation Mode with no transactions in the GT memory.	The operations are not available, when the GT memory is empty (refer to paragraph 2.7 Grand Totals Memory).

Message	Description	Troubleshooting
Zero not set!	Impossible to set the weight to zero.	To set the weight to zero, the platter/pan of the scale should be empty. If it is still impossible to set the weight to zero with the empty platter/pan, contact the system administrator.
Tare not set!	Tare weight or the total tare weight value out of range (exceed Tare Max Weight value indicated on the special sticker under the display of the scale).	Use tare of appropriate weight, or stop multiple tare-out operations.
Can't set tare value!	Tare weight value has already been entered manually or by weighing it on the scale.	It is necessary to discard the tare weight value entered by measuring it on the scale or manually with numeric keys, in order to call an item with a preset tare weight (refer to paragraph 2.3 Entering Tare Weight).
	When entering tare weight with numeric keys, zero tare weight value was set.	Enter non-zero tare weight value with the numeric keys.
Operation forbidden!	Returned to an attempt to override item unit price, when this function is disabled.	Contact the system administrator.
	Returned to an attempt to save a new item unit price to PLU, when this function is disabled.	
	Returned to an attempt to print a GT label in Grand Totals Mode, when this function is disabled.	
Invalid PLU number!	The entered PLU number is out of range in this scale.	Enter a correct PLU number. Check with the system administrator the PLU number of the wanted item.
	Returned to an attempt to call up an item with a quick access key.	Quick access key is programmed to call up a PLU with an invalid number. Contact the system administrator.
Can't access PLU!	Impossible to get item data when selecting it, or the error is returned to an attempt to save item unit price to PLU.	Contact the system administrator.
Empty PLU XXXXX	Returned to an attempt to call up a PLU containing no data.	PLU with this number has not been programmed in the database or has been deleted. Contact the system administrator.
Item not found!	The item with the entered number was not found when calling it up by its code.	Contact the system administrator.
Invalid PLU data!	Some data of the called up PLU is out of range.	Contact the system administrator.
Function failed!	Error occurred while executing a function assigned to the pressed quick access key.	Contact the system administrator.

Message	Description	Troubleshooting
Autoprinting disabled!	Returned to an attempt to enter Autoprinting Threshold Program Mode with a quick access key, when automatic label printing is disabled by the system administrator.	Contact the system administrator.
Invalid unit price!	Returned to an attempt to call up a preset unit price value with a quick access key.	The quick access key is programmed with an invalid unit price value. Contact the system administrator.
Invalid item code!	The entered item code value is out of range.	Enter a valid item code value.
	Returned to an attempt to call up an item by its code with a quick access key.	The quick access key is programmed with an invalid item code value. Contact the system administrator.
Exchange rate not set!	Returned to an attempt to enter Secondary Currency Cost Equivalent Mode with the currency exchange rate not set.	To enter Secondary Currency Cost Equivalent Mode, set the currency exchange rate (refer to paragraph 2.9.6 Currency Exchange Rate).
PLU not selected!	Returned to an attempt to save a new unit price to PLU/in Arbitrary Bar Code Input Mode/to print a label/to add a transaction to the GT memory, if no PLU is selected and it is not allowed to set manually unit price.	To perform these actions, select an item first (refer to paragraphs 2.9.2 Saving Unit Price to Scale PLU Memory/2.9.9 Arbitrary Bar Code/2.5 Printing Labels/2.7 Grand Totals Memory).
Can't add to GT Memory	Impossible to add another transaction to the GT memory.	The GT memory (GT sales amount, GT weight, or GT transactions) is overflowed, or the operator attempts to add sales amount or weight equal to "0".
Can't void transaction	Returned to an attempt to void more than one transaction from the GT memory, or the GT memory is empty.	The scale allows voiding only the last transaction added to the GT memory. If it is necessary to void several transactions, clear the GT memory and add the transactions once again.
Invalid bar code!	Returned to an attempt to enter an invalid bar code in Arbitrary Bar Code Input Mode.	Enter a valid bar code (refer to paragraph 2.9.9 Arbitrary Bar Code).
Invalid password!	This error is returned to an attempt to enter the System Menu.	The System Menu is designed for the system administrator. If an operator has mistakenly pressed the key  and entered the prompt to input password to access the System Menu, press the key  to return to the normal operating mode.
Error XXX	The display shows the number of the error.	Contact the system administrator.

### 3.3 Printing Errors

Table 3

Message	Description	Troubleshooting
PLU not selected!	This error may occur in an attempt to print a label.	This operation requires an item to be selected first. Manually entered unit price is disabled by the system administrator.
	This error may occur in an attempt to add a transaction to the GT memory.	
Weight not stable!	May occur in an attempt to print a label, when the weight is less than Min.	To print a label, weight has to be stable and be within the range between Min and Max. Min and Max values are indicated on the special sticker under the display.
Error XXX	The display shows the number of the error.	Contact the system administrator.
Settings error XXX	The display shows the number of the error.	Contact the system administrator.
No paper!	No paper in the printing mechanism.	Load a new paper roll, make sure the paper is loaded properly (refer to paragraph 1.7 Loading Paper in Printing Mechanism).
No label found!	The printer failed to identify a label on the paper.	Press the key  several times. Paper should be fed by one label at a time. If the scale returns the same error while feeding label paper, check whether paper is properly loaded and the printer slot is clean (refer to paragraph 1.7 Loading Paper in Printing Mechanism).
Printer head open!	The head of the printer is not closed.	Bring together the closing levers of the thermal head until you hear a click (refer to paragraph 1.7 Loading Paper in Printing Mechanism). Press the key  for the printer to identify the beginning of a label.
Remove the label!	The last printed label has not been removed, or paper is not wound around the take-up unit.	Remove the printed label. If it is required to print labels without removing them from the line (paper is not wound around the take-up unit), contact the system administrator.
Printer overheated!	The thermal head overheated while printing.	If the thermal head has got overheated because of continuous operation, let it cool for several minutes. If it did not help, contact the system administrator.
Empty label format!	The label format selected by the system administrator, has zero length.	Contact the system administrator.
RTC error!	Internal real-time clock failure.	Contact the system administrator. Label printing and sales recording are disabled.
Date-time error!	System error.	Contact the system administrator.
Messages error!	System error.	Contact the system administrator.
Bar code error!	Error when generating a bar code (fields lengths conflict of the selected by the system administrator bar code structure and the data used for printing)	Contact the system administrator.

<b>Message</b>	<b>Description</b>	<b>Troubleshooting</b>
Invalid quantity!	Quantity value error for a non-weight item.	System error. Contact the system administrator.
Invalid weight!	Weight value error.	System error. Contact the system administrator.
Invalid tare!	Tare weight value error.	System error. Contact the system administrator.
Invalid unit price!	Unit price value error.	System error. Contact the system administrator.
Invalid cost!	Cost value error.	System error. Contact the system administrator.
Zero cost!	Calculated cost value is zero.	Enter unit price or select an item. In Non-Weight Item Mode, enter quantity of the item in pcs.
Incomplete printing!	This error may occur, if the label format selected by the system administrator, does not match the label paper loaded in the printer.	The length of the label selected in the scale settings is bigger than the length of the labels loaded into the printer. Load a proper label paper (refer to paragraph 1.7 Loading Paper in Printing Mechanism), or contact the system administrator.
Label copy forbidden!	Returned to an attempt to print a copy of a label for a weight item.	It is not allowed to print label copies for weight items.